



# Q2B® ELECTRO-MECHANICAL SIREN

## > Features

- Improves emergency vehicle operator safety.
- 123 decibels at 10 feet.
- Chrome plating and highly polished stainless steel.
- "Worry free" coaster clutch.
- Quality and reliability.



### "It's not a fire truck unless it's got a Q-Siren."

With more than 50 years of fire service tradition and history, the Federal Signal Q2B® electro-mechanical siren is a beautifully streamlined, chrome-plated siren designed to provide unparalleled reliability for long-life operation. When mounted on emergency vehicles, the Q2B delivers powerful warning sound, more than any other electro-mechanical siren.

A heavy-duty coaster clutch is standard on Q2B models. The unique coaster clutch design enables the siren to deliver longer coast-down sound once power is removed to reduce battery drain. The "worry free" clutch is subject to very little wear and requires no service attention or adjustments. Use the standard electric brake to quickly silence the siren.

Two Q2B models are available. The Q2B-P comes with pedestal and housing for bumper mounting. Q2B-NN is designed for recessed mounting in the bumper.

For increased convenience, the Q2FSK foot switch kit is also available. The kit comes with everything necessary to wire a footswitch to any Q2B model enabling the operator to power the siren "hands-free."

For flat and curved apparatus bumpers, a special bracket, the Q-MT is available. This rugged, durable mount is easy to install. Constructed of tough 3/8-inch steel, the Q-MT design protects the siren from the impact of rough roads.



*Q2B-P - Q-Siren with pedestal mount and back housing.*

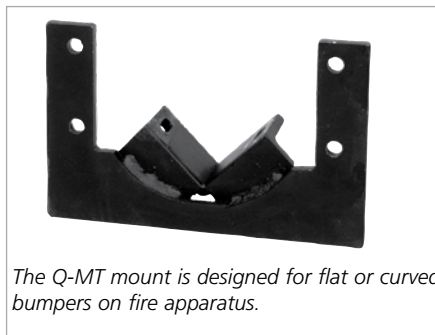

*The Q-MT mount is designed for flat or curved bumpers on fire apparatus.*

The distinctive sound of the Q2B electro-mechanical siren is a registered trademark owned by Federal Signal Corporation.

> How to Order

1. Specify model.

- Q2B-P** Q-Siren® with pedestal mount and housing
- Q2B-NN** Q-Siren without pedestal mount or housing (designed for recess mounting)

2. Specify accessories (optional).

- Q-MT** Recess mount bracket for Q-Siren
- Q2FSK** Foot switch kit for Q-Siren

Specifications	
Voltage	12 VDC
Operating Current	100A
Sound Output	123 dB @ 10ft.
Physical Specifications	
Length	14.0 in (35.6 cm)
Diameter	10.0 in (25.4 cm)
Height	10.5 in (26.7 cm)
Ship Weight	
	49.0 lbs (23.0 kg)

**Official Federal Signal Q-Siren gear**  
Purchase at: [www.q-gear.net](http://www.q-gear.net)

**MOUNTING DIAGRAM FOR PEDESTAL MOUNT**

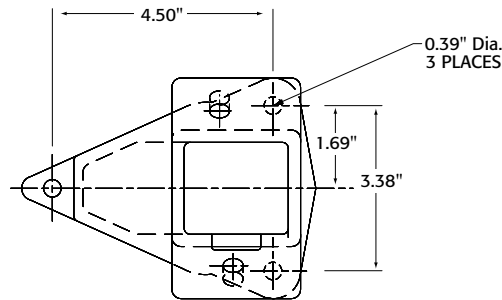

**BUMPER CUTOUT FOR Q-SIREN (Q-MT)**

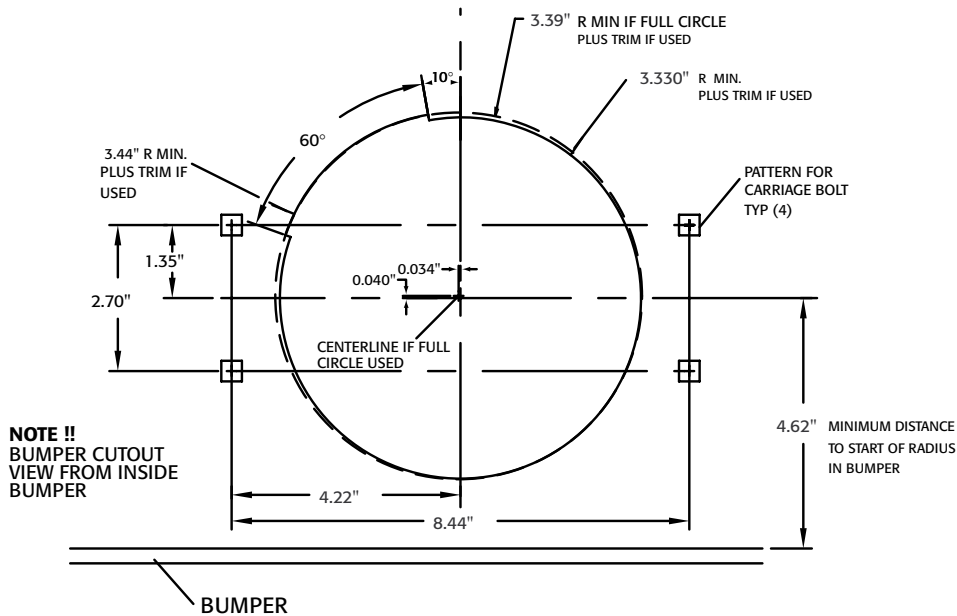

Warning: Sirens and Speakers may produce LOUD sounds necessary to request the right-of-way. Sirens and Speakers may cause hearing damage. Wear hearing protection.

Q2B is a trademark of Federal Signal Corporation. The distinctive sound of the Q2B electro-mechanical siren is a registered trademark owned by Federal Signal Corporation.